

Direction Finding and Monitoring Antenna

20 – 6000 MHz

Product Code: DF-A0173

VERSION: 1.4

SPECIFICATIONS:

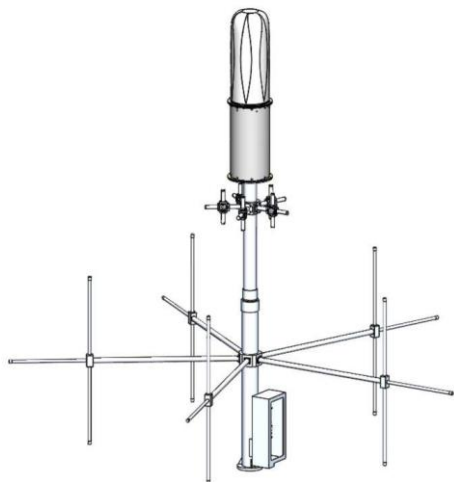

PRODUCT DESCRIPTION:

The DF-A0173 direction finding antenna covers a frequency range of 20 MHz to 6 GHz. A separate, but fully integrated active monitoring antenna gives high sensitivity omni-directional coverage on the same axis as the DF antenna, without interfering with the DF array.

The full-size elements on all bands give excellent DF sensitivity. Ultimate angular resolution for strong signals is well under 1° for most of the frequency range. Dipole elements provide good cross-polarisation rejection, and fair performance for signals arriving from up to 15° above or below the horizon.

The DF-A0173 is capable of HP and VP DF, selectable for Band A and B, with each polarisation requiring characterisation. Two outputs are provided per element in each of bands A and B, one each per polarisation.

The integrated monitoring antenna is in two bands, mounted above the Band C & D DF antenna module housed in the radome. Each band of the monitoring array is amplified at the top of the cable, and passively combined to give continuous coverage over the frequency range 20 MHz to 6 GHz, with a single output connector.

This DF antenna is designed to be usable with either a 5- or 2-channel phase-sensitive receiver and correlative algorithm. Characterisation of the antenna can be performed on request.

Related products: DF-A0062, DF-A0085 and DF-A0038

Product codes:	
DF-A0173	DF with monitoring up to 6 GHz
Electrical - DF:	
DF frequency range	Band A: 20 – 300 MHz; Band B: 300 – 1300 MHz; Band C: 1000 – 3000 MHz; Band D: 3000 – 6000 MHz
Nominal input impedance	50 Ω
Antenna type	5-element DF interferometer
Polarisation:	
Band A	Vertical & Horizontal
Band B	Vertical & Horizontal
Band C	Vertical
Band D	Vertical
Output cables	RG 400 cables
DF connectors	30 x SMA male
Monitoring connector	1 x N-type male
Electrical - monitoring:	
Frequency range	20 – 6000 MHz
Nominal H-plane beamwidth	360°
Nominal E-plane beamwidth	60°
Typical VSWR*	< 2:1
Polarisation	Vertical
Nominal impedance	50 Ω
Input voltage (via coax)*	13 – 24 V DC
Input current*	< 150 mA
Power consumption (nom)*	< 2.25 W
OP1dB (typ.)*	> 11 dBm
OIP2 (typ.)*	> 31 dBm
OIP3 (typ.)*	> 21 dBm
Mechanical:	
Cross-sectional wind area	1.55 m ² (including antenna switch)
Maximum wind speed	160 km/h (without ice load)
Assembled height	3.60 m
Assembled diameter (max)	3.80 m
Shipping dimensions	2.20 m x 0.90 m x 0.60 m
Weight of antenna	75 kg
including shipping container	150 kg

*in active mode

ELECTRICAL FEATURES:

- Full-size DF
- Wideband DF
- Dual-polarised
- 5-element interferometer
- High sensitivity omni antenna integrated

MECHANICAL FEATURES:

- Designed for tower-mounting

Direction Finding and Monitoring Antenna

20 – 6000 MHz

Product Code: DF-A0173

VERSION: 1.4

ANTENNA DIAMETER AND INTERFACE FLANGE DIMENSIONS:

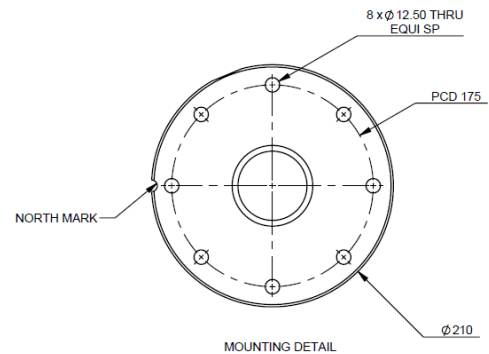
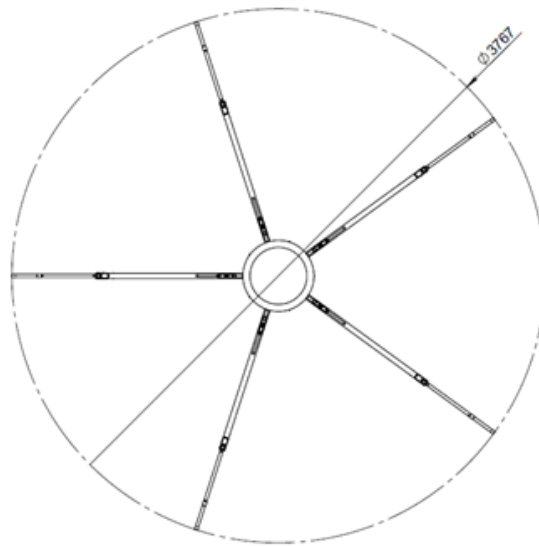

ENVIRONMENTAL SPECIFICATIONS AND TESTS (designed to meet the following):

Vibration	Designed for MIL-STD-810E method 516.4, category 8
Mechanical shock	Designed for MIL-STD-810E method 516.4 (40 g)
Low temperature storage	Designed for MIL-STD-810E method 502.3 (-30 °C)
High temperature storage	Designed for MIL-STD-810E method 501.3 (+70 °C)
Rain	Designed for MIL-STD-810E 506.3 procedure I (95% RH)
Artificial weathering (UV stability) total duration 500 h	Designed for BS 3900: part F16, method A. lamps: UV-B (313) Product exceeds requirements set out by the British Standard
Temperature and humidity	Designed for MIL-STD-810E method 507.3
Salt / fog	Designed for MIL-STD-810E 509.3 procedure I
Dust	Designed for MIL-STD-810E 510.3 procedure II

Direction Finding and Monitoring Antenna

20 – 6000 MHz

Product Code: DF-A0173

VERSION: 1.4

DF SENSITIVITY BAND A:

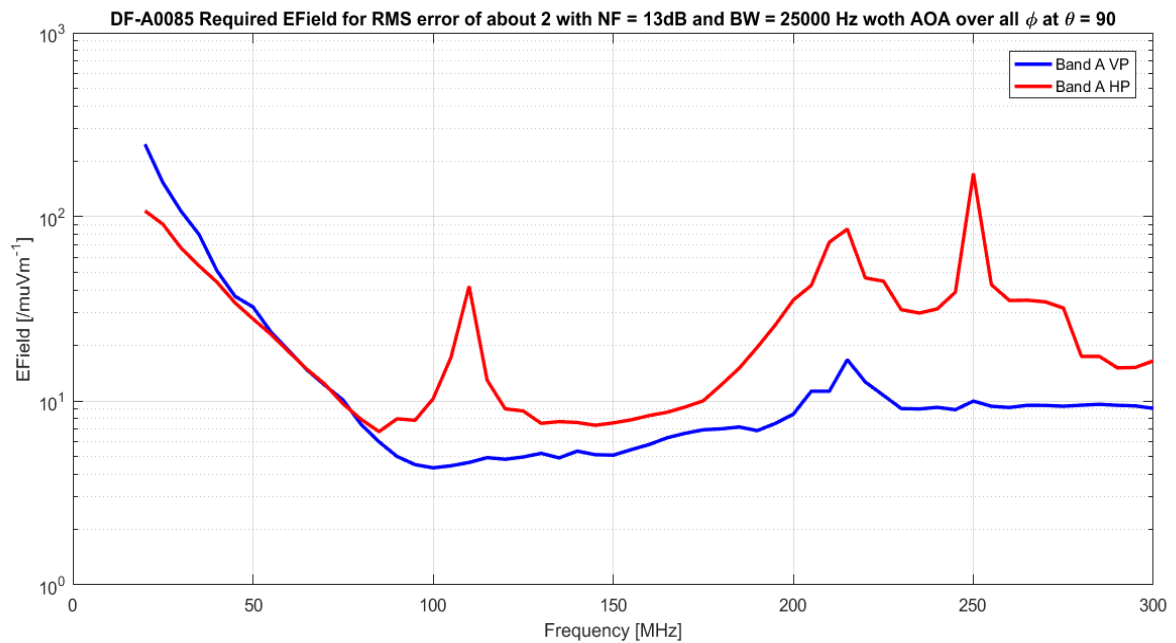

DF SENSITIVITY BAND B:

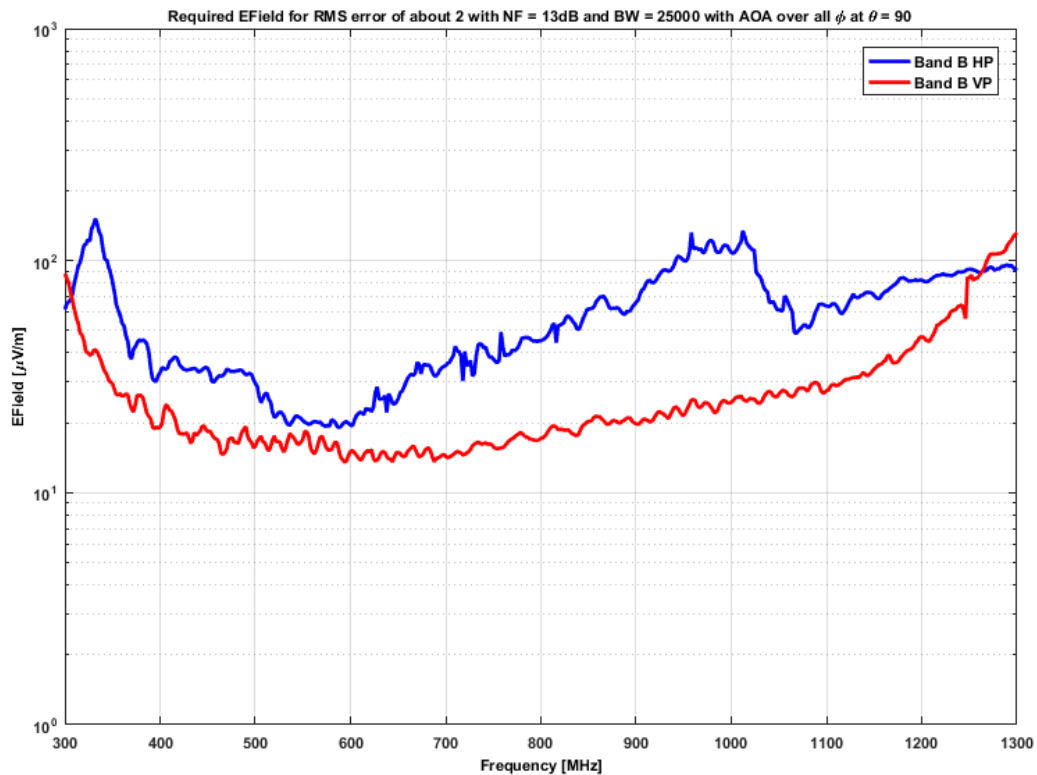

Direction Finding and Monitoring Antenna

20 – 6000 MHz

Product Code: DF-A0173

VERSION: 1.4

VERTICAL POLARISATION DF SENSITIVITY GRAPH:

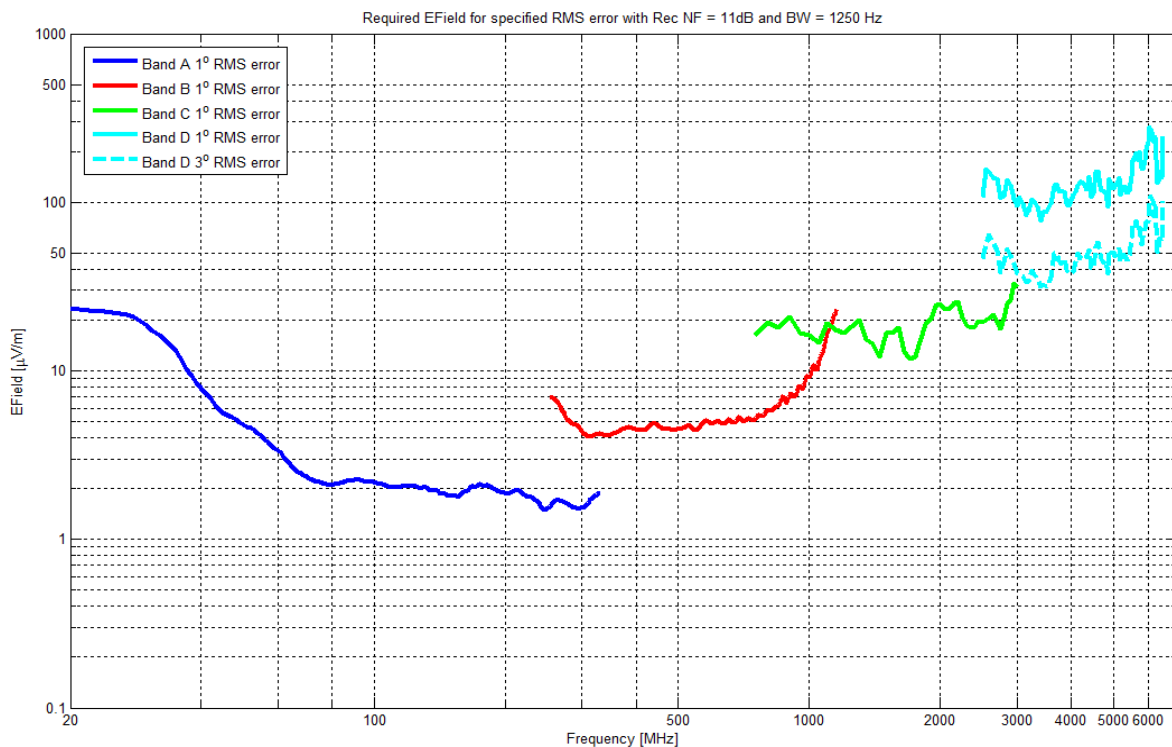

The graph illustrates the direction finding sensitivity of a typical system. The sensitivity is measured using an IF bandwidth of 1.25 kHz and **without** averaging. The graph shows the minimum signal required to obtain a bearing fluctuation of less than 1° for the frequency range 20 to 6000 MHz, less than 3° for the frequency range 3000 to 6000 MHz. **The values should be adapted for the system in question if it uses a different bandwidth and receiver noise figure, or if considering a different required accuracy.**

INTEROPERABILITY WITH DF RECEIVERS:

The DF sensitivity of the full system is highly dependent on the receivers, processing and algorithm used, as well as the characterisation table density. The graph above assumes a 5-channel, low noise receiver and correlative algorithm. The sensitivity will be between 1 and 10 dB worse with a 2-channel receiver system.

The 1 to 6 GHz band of this antenna is designed for efficient operation with a commutated 2-channel receiver.

Special attention has been paid to the nulls which usually occur in this band due to the large diameter mast. Receiver systems with two channels, commutated to measure five antennas, are sensitive to nulls in the element patterns. Depending on the receiver and algorithm, reducing the null depth leads to a more reliable system.

Direction Finding and Monitoring Antenna

20 – 6000 MHz

Product Code: DF-A0173

VERSION: 1.4

GAIN OF OMNI-DIRECTIONAL MONITORING ANTENNA:

